

SERIES AVP and AVN PLUG-IN DC-DC CONVERTERS

High Output Voltage: 6,000 VDC to 10,000 VDC
High Reliability
Ultra-Miniature - Low Profile

This series of unregulated high voltage DC-DC converters with output voltages to 10,000 VDC are produced in an ultra-miniature encapsulated package. 50 different standard models are available. These single output units will operate over the temperature range of -25° C to +70° C with no heat sink or electrical derating. For military applications an operating temperature range -55° C to +85 ° C is available. An optional environmental screening package per MIL-STD-883 is also available.

FEATURES

- Output Voltages: 6,000 VDC to 10,000 VDC
- 1.25 watt output at 70° ambient
- Ultra-miniature size 0.500" height, 5.0 grams weight, 0.25 cubic inches volume
- 5 input voltage ranges 5, 12, 15, 24 and 28 VDC
- Transformer Isolated Design
- MIL-STD 883 options available
- No heat sink or electrical derating required

OPTIONS AVAILABLE

- Per Mil. Std. 883
- Expanded operating temp. (-55° C to +85° C)
- Stabilization Bake (125° C ambient) - Method 1008
- Temperature Cycle (-55° C to +125° C) - Method 1010, Condition B
- Hi Temp, Burn-In - Method 1015 as a guide

TYPICAL CHARACTERISTICS:

- **Test conditions:** 25° C ambient and input voltage at nominal value unless otherwise specified.
- **LINE REGULATION:** OUTPUT IS DIRECTLY PROPORTIONAL TO THE INPUT.
- **Input voltage range:** ±10% all models
- **Output voltage tolerance at full load-nom. Input:** ±3%
Please keep loaded to minimum of 10% at all times.
Note: For tighter output voltage tolerances, please consult factory.
- **Converter frequency:** 20 - 40 KHz
- **Output temperature coefficient:** 0.05%/°C for all models
- **Operating temperature:** -25° C to +70° C ambient. No heat sink is required.
- **Storage temperature:** -55° C to +125° C

SERIES AVP - SINGLE OUTPUT COMMON GROUND POSITIVE OUTPUT

For use when input and output grounds are connected and a positive output voltage is required

PICO Plug-in Part Number	Input Voltage (V DC)	Output Voltage (V DC)	** Max. Load Current (mA)	Max. Output Power (watts)	Eff. @ Full Load Typical (%)	Input Current Full Load Typical (mA)	* Output Volt. Ripple @ Full Load (Vp-p max)	Full Load Output Volt. Tolerance (±%)	Price (US \$)
5AVP6K	5	+6000	0.208	1.25	74	338	150	3	302.18
5AVP7K	5	+7000	0.179	1.25	74	338	150	3	320.32
5AVP8K	5	+8000	0.156	1.25	73	342	160	3	339.53
5AVP9K	5	+9000	0.139	1.25	72	347	180	3	359.90
5AVP10K	5	+10000	0.125	1.25	70	357	200	3	381.50
12AVP6K	12	+6000	0.208	1.25	77	135	150	3	302.18
12AVP7K	12	+7000	0.179	1.25	76	137	150	3	320.32
12AVP8K	12	+8000	0.156	1.25	76	137	150	3	339.53
12AVP9K	12	+9000	0.139	1.25	75	139	180	3	359.90
12AVP10K	12	+10000	0.125	1.25	74	141	200	3	381.50

15AVP6K	15	+6000	0.208	1.25	76	110	150	3	302.15
15AVP7K	15	+7000	0.179	1.25	75	111	150	3	320.32
15AVP8K	15	+8000	0.156	1.25	74	113	160	3	339.53
15AVP9K	15	+9000	0.139	1.25	73	114	180	3	359.90
15AVP10K	15	+10000	0.125	1.25	73	114	200	3	381.50
24AVP6K	24	+6000	0.208	1.25	76	69	150	3	302.18
24AVP7K	24	+7000	0.179	1.25	76	69	150	3	320.32
24AVP8K	24	+8000	0.156	1.25	76	69	160	3	339.53
24AVP9K	24	+9000	0.139	1.25	76	69	180	3	359.90
24AVP10K	24	+10000	0.125	1.25	75	70	200	3	381.50
28AVP6K	28	+6000	0.208	1.25	75	60	150	3	302.18
28AVP7K	28	+7000	0.179	1.25	75	60	150	3	320.32
28AVP8K	28	+8000	0.156	1.25	75	60	160	3	339.53
28AVP9K	28	+9000	0.139	1.25	75	60	180	3	359.90
28AVP10K	28	+10000	0.125	1.25	75	60	200	3	381.50

* Additional Capacitor up to 470 pf can be placed across the output for further Ripple reduction.

** Maintain at least 10% of load at all times to prevent voltage surge.

Ordering Instructions: No minimum. Net 30 days F.O.B. Pelham, New York

SAFETY NOTE: The high voltage power supplies described in this datasheet generate voltages which can be lethal. They should only be installed and used by personnel who have received the appropriate training and who are fully aware of the hazards that exist.

Series AVP Single Output

For use when input and output grounds are connected and a positive output voltage is required

AVP - SINGLE OUTPUT

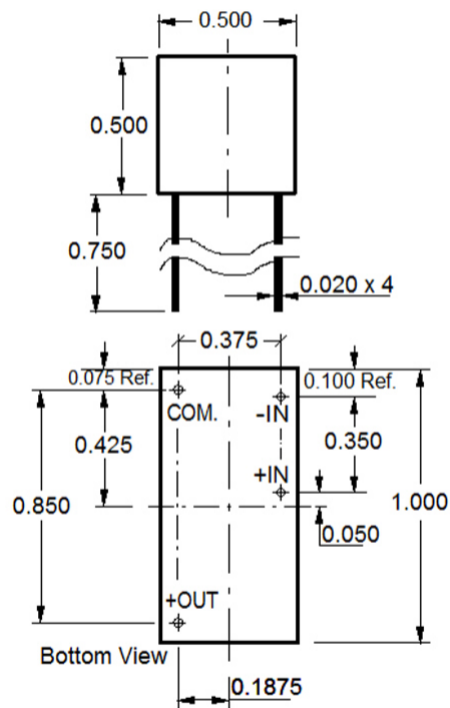

Weight: 9.5 Grams Typical
Measurements are in Inches

SERIES AVP - LOAD

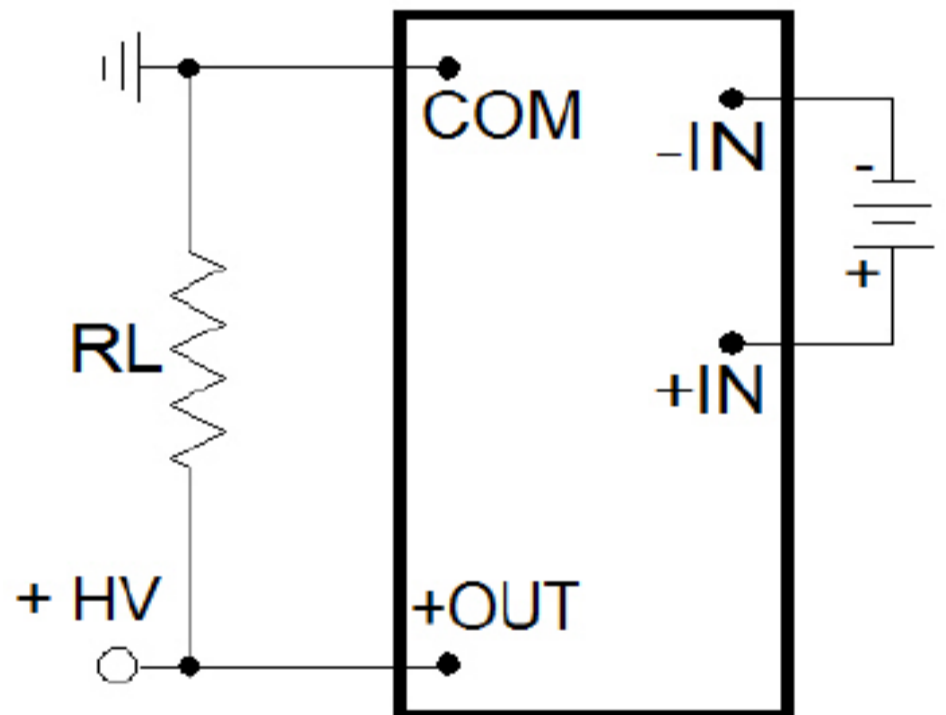

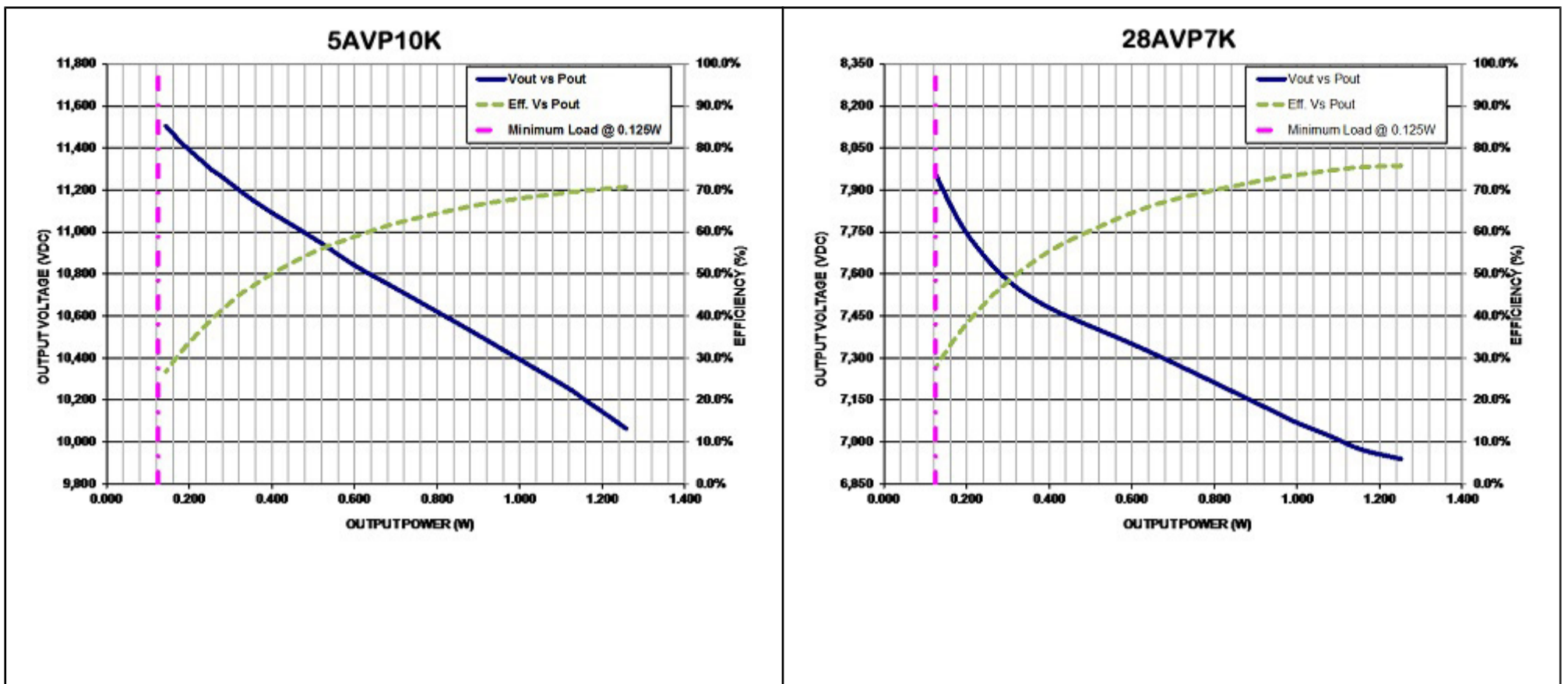

SERIES AVN - SINGLE OUTPUT COMMON GROUND NEGATIVE OUTPUT

For use when input and output grounds are connected and a negative output voltage is required

PICO Plug-in Part Number	Input Voltage (V DC)	Output Voltage (V DC)	** Max. Load Current (mA)	Max. Output Power (watts)	Eff. @ Full Load Typical (%)	Input Current Full Load Typical (mA)	* Output Volt. Ripple @ Full Load (Vp-p max)	Full Load Output Volt. Tolerance (±%)	Price (US \$)
5AVN6K	5	-6000	0.208	1.25	74	338	150	3	302.18
5AVN7K	5	-7000	0.179	1.25	74	338	150	3	320.32
5AVN8K	5	-8000	0.156	1.25	73	342	160	3	339.53
5AVN9K	5	-9000	0.139	1.25	72	347	180	3	359.90
5AVN10K	5	-10000	0.125	1.25	70	357	200	3	381.50
12AVN6K	12	-6000	0.208	1.25	77	135	150	3	302.18
12AVN7K	12	-7000	0.179	1.25	76	137	150	3	320.32
12AVN8K	12	-8000	0.156	1.25	76	137	160	3	339.53
12AVN9K	12	-9000	0.139	1.25	75	139	180	3	359.90
12AVN10K	12	-10000	0.125	1.25	74	141	200	3	381.50
15AVN6K	15	-6000	0.208	1.25	76	110	150	3	302.15
15AVN7K	15	-7000	0.179	1.25	75	110	150	3	320.32
15AVN8K	15	-8000	0.156	1.25	74	113	160	3	339.53
15AVN9K	15	-9000	0.139	1.25	73	114	180	3	359.90
15AVN10K	15	-10000	0.125	1.25	73	114	200	3	381.50
24AVN6K	24	-6000	0.208	1.25	76	69	150	3	302.18
24AVN7K	24	-7000	0.179	1.25	76	69	150	3	320.32
24AVN8K	24	-8000	0.156	1.25	76	69	160	3	339.53
24AVN9K	24	-9000	0.139	1.25	76	69	180	3	359.90
24AVN10K	24	-10000	0.125	1.25	75	70	200	3	381.50
28AVN6K	28	-6000	0.208	1.25	75	60	150	3	302.18
28AVN7K	28	-7000	0.179	1.25	75	60	150	3	320.32
28AVN8K	28	-8000	0.156	1.25	75	60	160	3	339.53
28AVN9K	28	-9000	0.139	1.25	75	60	180	3	359.90
28AVN10K	28	-10000	0.125	1.25	75	60	200	3	381.50

* Additional Capacitor up to 470 pf can be placed across the output for further Ripple reduction.

** Maintain at least 10% of load at all times to prevent voltage surge.

Ordering Instructions: No minimum. Net 30 days F.O.B. Pelham, New York

SAFETY NOTE: The high voltage power supplies described in this datasheet generate voltages which can be lethal. They should only be installed and used by personnel who have received the appropriate training and who are fully aware of the hazards that exist.

Series AVN Single Output

For use when input and output grounds are connected and a negative output voltage is required

AVN - SINGLE OUTPUT

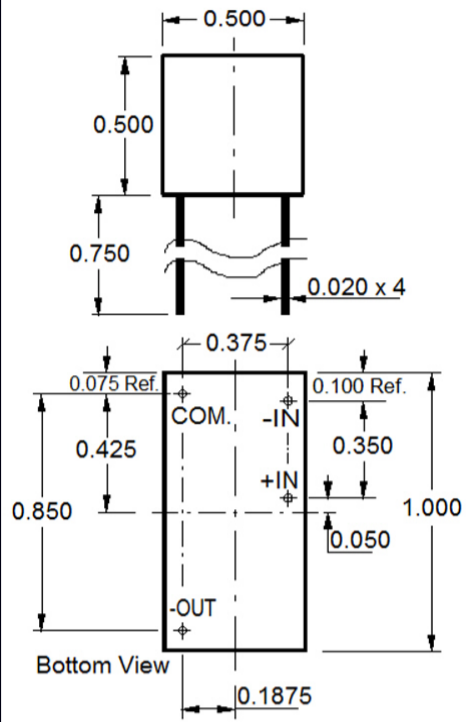

Weight: 9.5 Grams Typical
Measurements are in Inches

SERIES AVN - LOAD

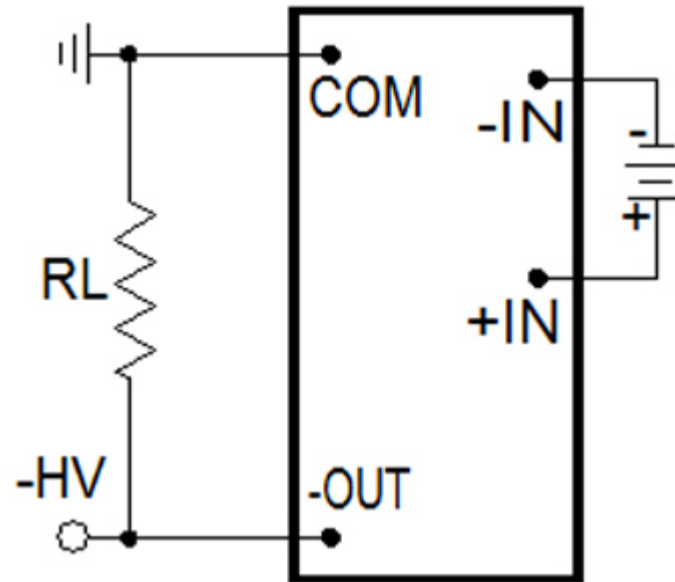

For immediate engineering assistance or to place an order:
Call Toll Free: 800-431-1064

PICO Electronics, Inc.

143 Sparks Ave. Pelham, NY 10803-1810
Tel: 914-738-1400 or Fax: 914-738-8225

[Go back to DC-DC Converters menu^{\[1\]}](#)