

INCH-POUND

MIL-PRF-21038/27E
W/AMENDMENT 3
1 August 2022
SUPERSEDING
MIL-PRF-21038/27E
W/AMENDMENT 2
26 February 2007

PERFORMANCE SPECIFICATION SHEET

TRANSFORMERS, PULSE, LOW POWER

This specification is approved for use by all Departments and Agencies of the Department of Defense.

The requirements for acquiring the products described herein shall consist of this specification and MIL-PRF-21038.

REQUIREMENTS:

Dimensions and configuration: See figure 1 and table 1.

Operating temperature: -55°C to +130°C.

Case: The case shall be nonmetallic (e.g., epoxy).

Weight: 5 grams, maximum.

Terminal strength: [MIL-STD-202-211](#), test condition A, 2 pounds applied force.

Terminals: Solderable printed circuit type terminals, see figure 1. Flat terminals can be used as an alternative to round terminals for configuration D and E only.

Comments, suggestions or questions on this document should be addressed to Defense Logistics Agency, Land and Maritime, ATTN: VAT, Post Office Box 3990, Columbus, OH 43218-3990), or emailed to Transformer@dla.mil. Since contact information can change, you may want to verify the currency of this address information using the ASSIST Online database at <https://assist.dla.mil>

AMSC N/A

DISTRIBUTION STATEMENT A. Approved for public release; distribution is unlimited.

FSC 5950



MIL-PRF-21038/27E
W/AMENDMENT 3

Electrical characteristics:

Turns ratio: See table I.

Common mode rejection (CMR): In accordance with table 1 when tested as specified on figure 2.

Pulse width of output: 2 microseconds nominal. The transformers shall be tested as specified on figure 3.

Overshoot and ringing: ± 1 volt maximum. The transformers shall be tested as specified on figure 4 with the resulting waveform shown on figure 5.

Droop: In accordance with table I when tested as specified on figure 4 with the resulting waveform shown on figure 5.

Rise time and fall time of output pulse: Shall be less than 150 nanoseconds except dash numbers -25, -26, -27, -30, and -31 shall be less than 250 nanoseconds maximum and dash numbers -9, -10, -15, -20, -24 shall be less than 200 nanoseconds maximum. The transformers shall be tested as specified on figure 3 with the resulting output waveform shown on figure 5.

Input impedance: The input impedance shall be as specified in table I when tested as specified on figure 5 at the frequencies of 75 kHz and at 1 MHz at $-55^{\circ}\text{C} \pm 2^{\circ}\text{C}$; $+25^{\circ}\text{C} \pm 2^{\circ}\text{C}$; and $+130^{\circ}\text{C} \pm 2^{\circ}\text{C}$.

DC resistance: The maximum dc resistance shall be in accordance with table I.

| Dielectric withstanding voltage: [MIL-STD-202-301](#), 100 V rms.

| Insulation resistance: [MIL-STD-202-302](#), test condition B. Not less than 1,000 megohms at 250 V dc.

| Shock (specified pulse): [MIL-STD-202-213](#), test condition I.

| Vibration, high frequency: [MIL-STD-202-204](#), test condition B.

Part or Identifying Number (PIN): Three levels of product are available in accordance with MIL-PRF-21038, level C, level M, and level T. For the use of flat terminals on configurations D and E, the letter "F" shall follow the part number. The PIN shall be coded as follows:

M21038/27-(dash no from table I) C denotes C level part with round terminals (e.g., M21038/27-01C)

M21038/27-(dash no. from table I) denotes M level part (e.g., M21038/27-01)

M21038/27-(dash no. from table I)TF denotes T level part with flat terminals (e.g., M21038/27-01TF)

Extension of qualification: Extension of qualification shall be in accordance with [MIL-PRF-21038](#).

Manufacturers may submit additional proposals for extension of qualification for review and approval by the qualifying activity. One way to obtain family approval of products in this specification is outlined below:

Qualify M21038/27-02 extends qualification to M21038/27-01 to -01 to -31.

Qualify M21038/27-12 extends qualification to M21038/27-11 to -20, and -27 and -31.

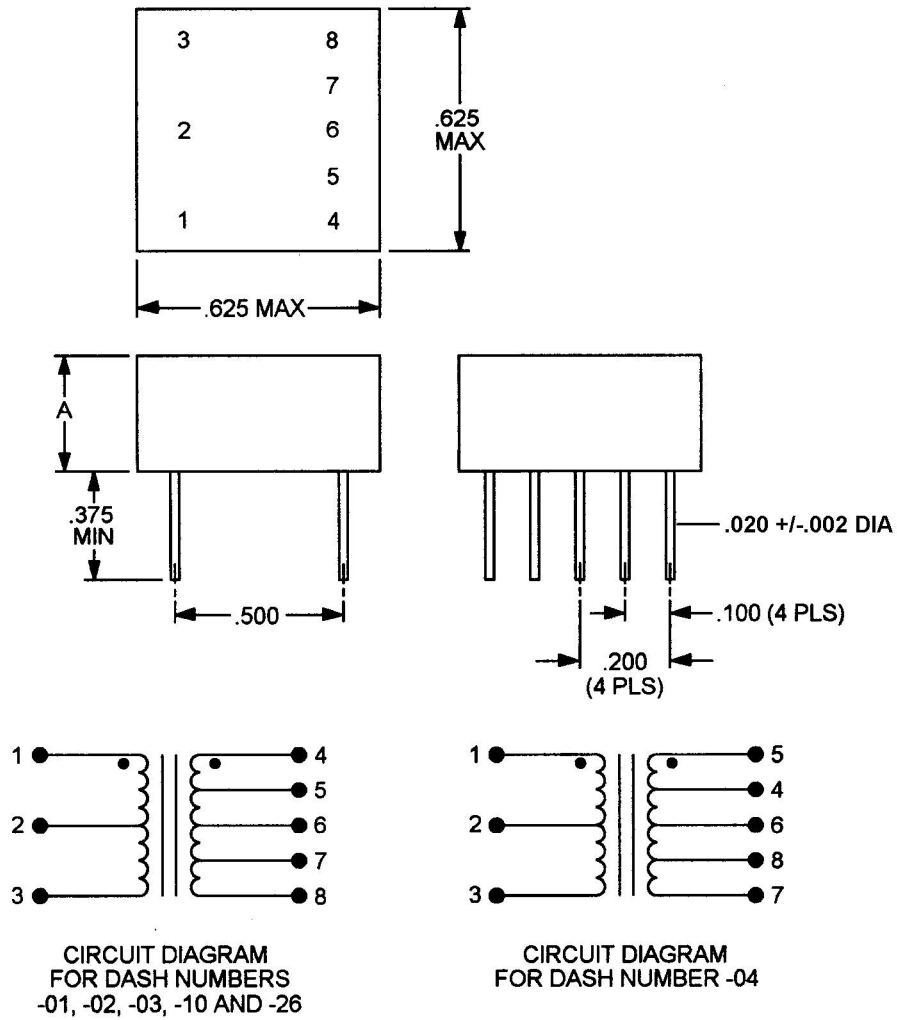

CONFIGURATION A

Dash no.	A max
-01, -04	.300
-02, -03, -10, -26	.250

FIGURE 1. Dimensions, configurations, and circuit diagrams.

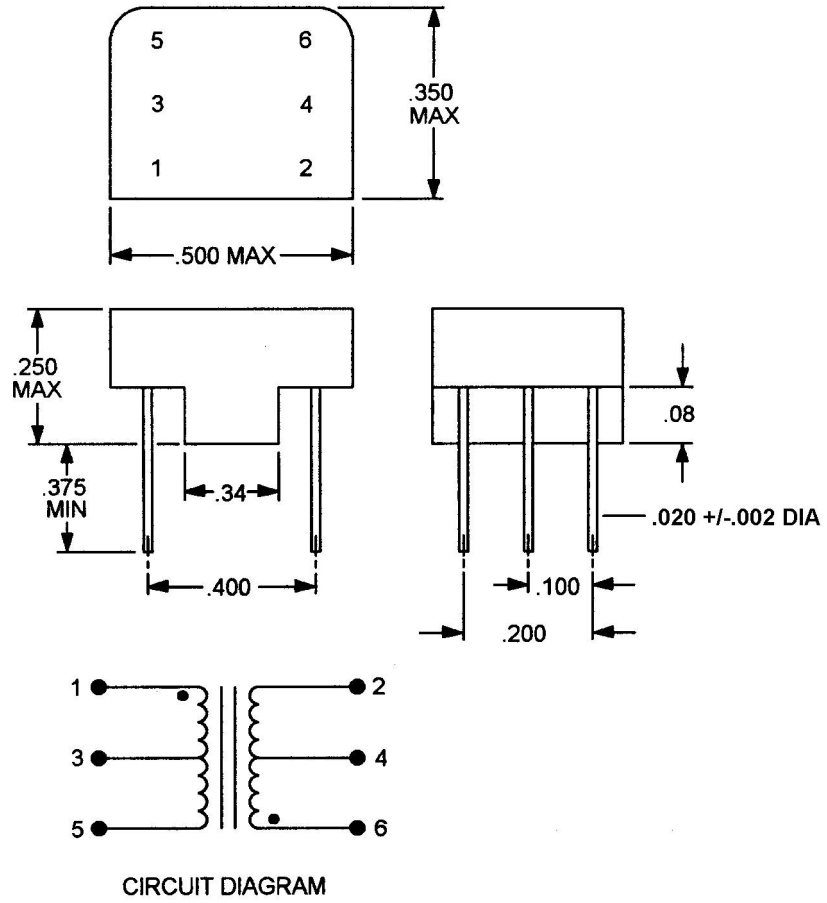

CONFIGURATION B

FIGURE 1. Dimensions, configurations, and circuit diagrams - Continued.

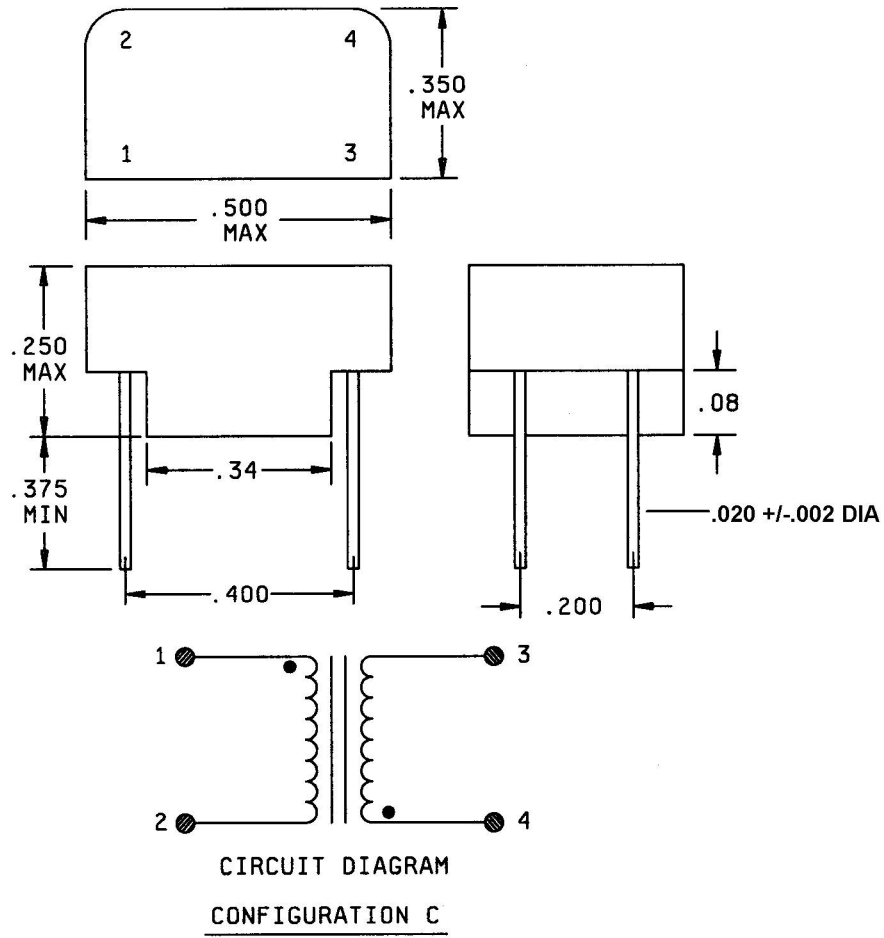
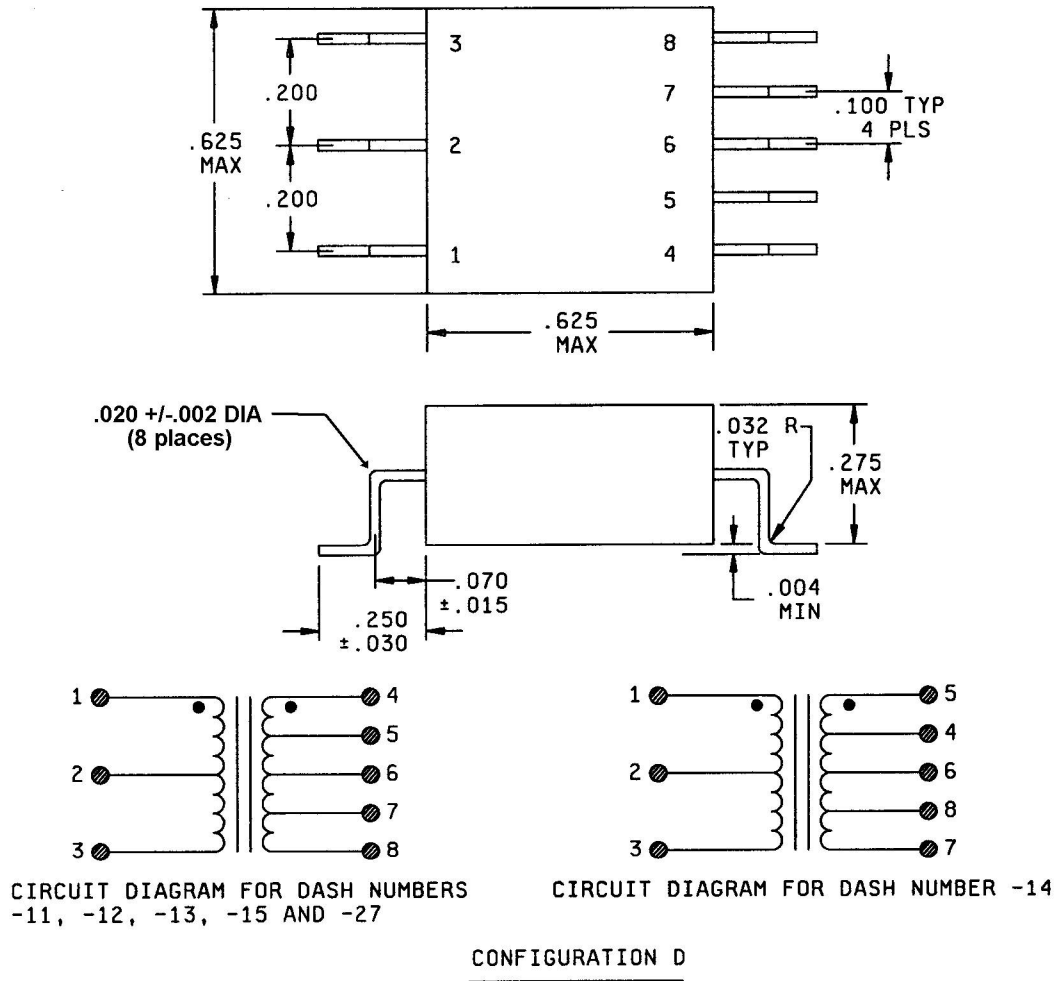

FIGURE 1. Dimensions, configurations, and circuit diagrams - Continued.

MIL-PRF-21038/27E
W/AMENDMENT 3



NOTE: Optional flat terminals (.020 x .020) can be used in place of the round through hole type terminals.

FIGURE 1. Dimensions, configurations, and circuit diagrams - Continued.

MIL-PRF-21038/27E
W/AMENDMENT 3

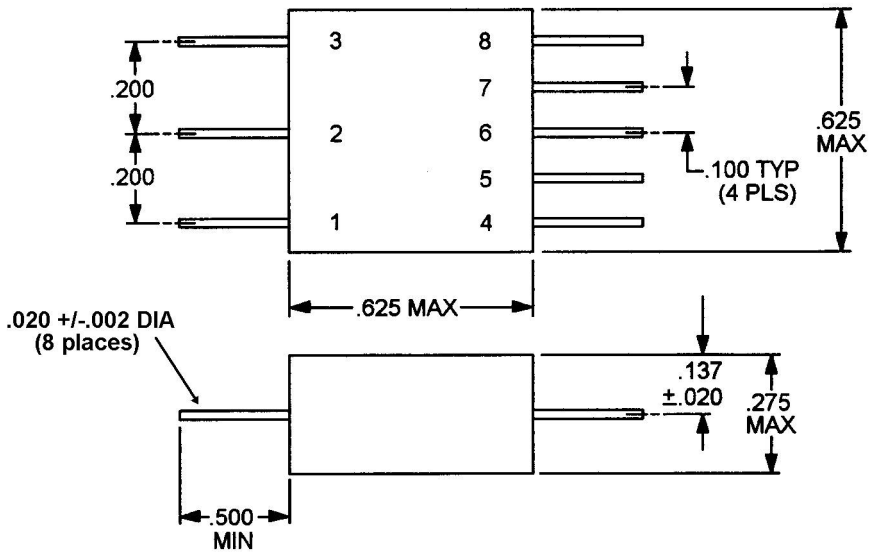

TOLERANCE .XXX = $\pm .008$

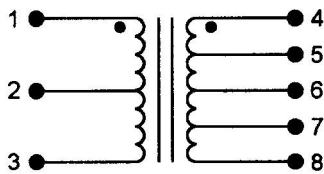

CIRCUIT DIAGRAM
FOR DASH NUMBERS
-16, -17, -18, -20 AND -31

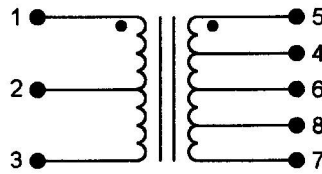

CIRCUIT DIAGRAM
FOR DASH NUMBER -19

CONFIGURATION E

NOTE: Optional flat terminals (.020 x .020) can be used in place of the round through hole type terminals.

FIGURE 1. Dimensions, configurations, and circuit diagrams - Continued.

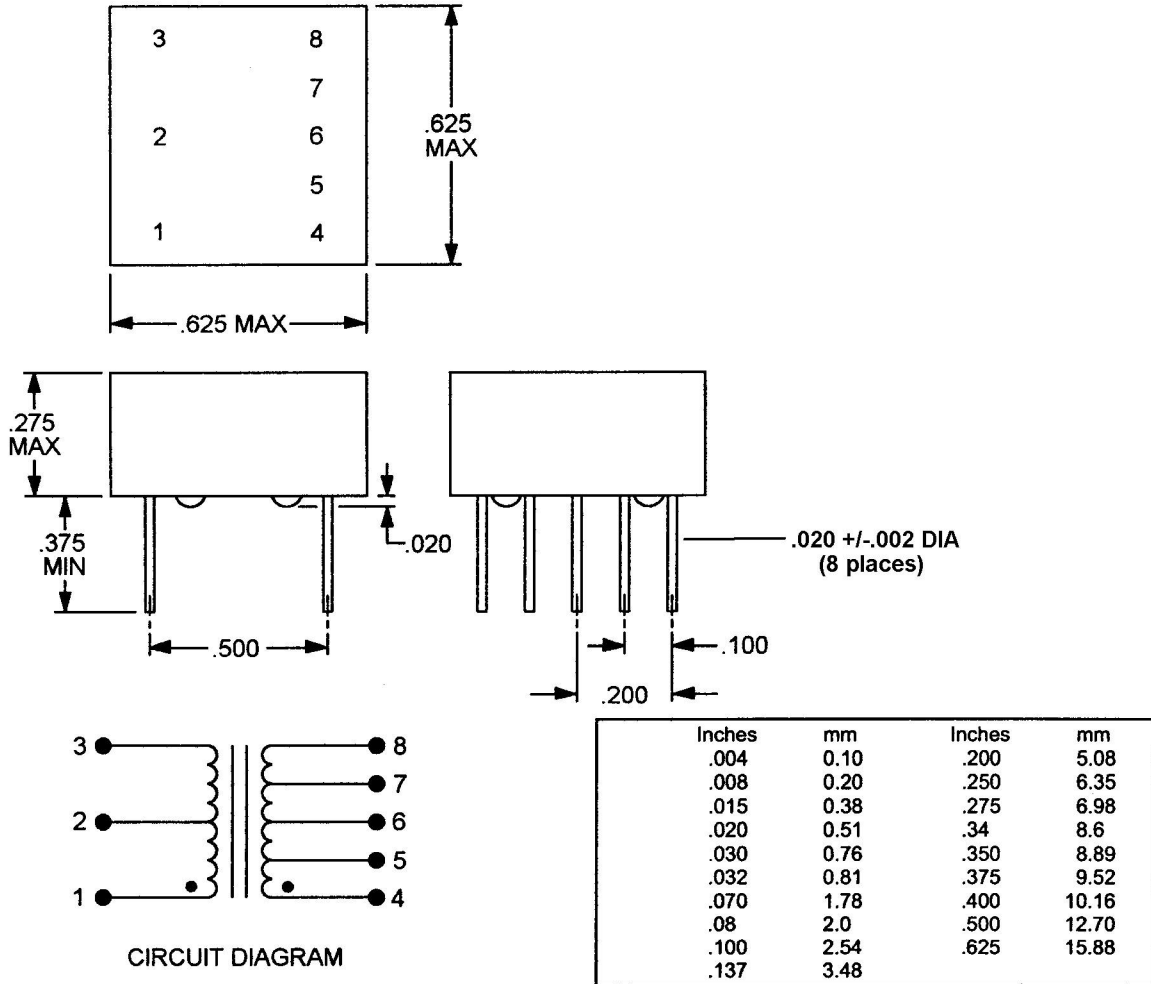

CONFIGURATION F

NOTES:

1. Dimensions are in inches.
2. Metric equivalents are given for general information only.
3. Unless otherwise specified, tolerance is ± 0.010 inch (0.25 mm).
4. Marking shall be on top of the case, unless space is insufficient then marking can appear on the sides.
5. Terminal identification shall be marked on the transformer as shown.
6. Standoff location is for reference only.

FIGURE 1. Dimensions, configurations, and circuit diagrams - Continued.

MIL-PRF-21038/27E
W/AMENDMENT 3

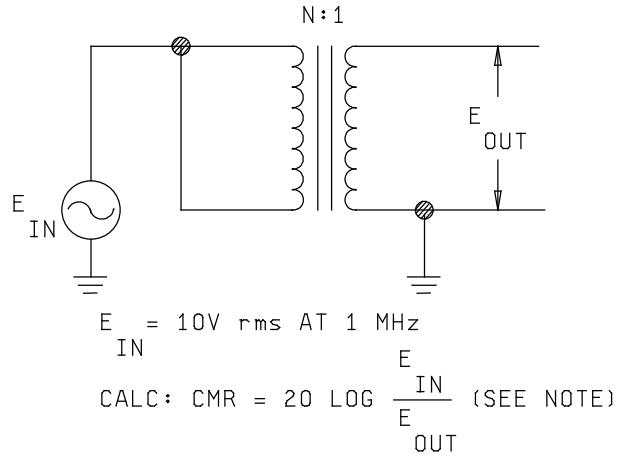

FIGURE 2. Test circuit for common mode rejection.

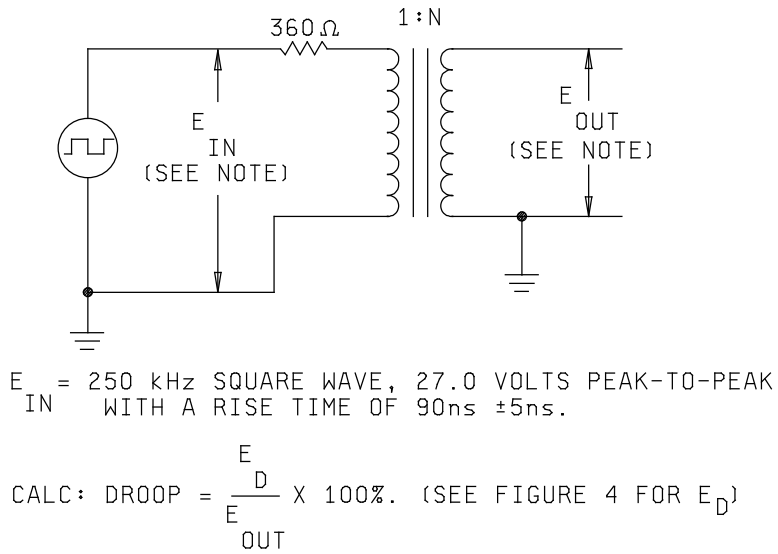

FIGURE 3. Test circuit for droop, rise time, pulse width.

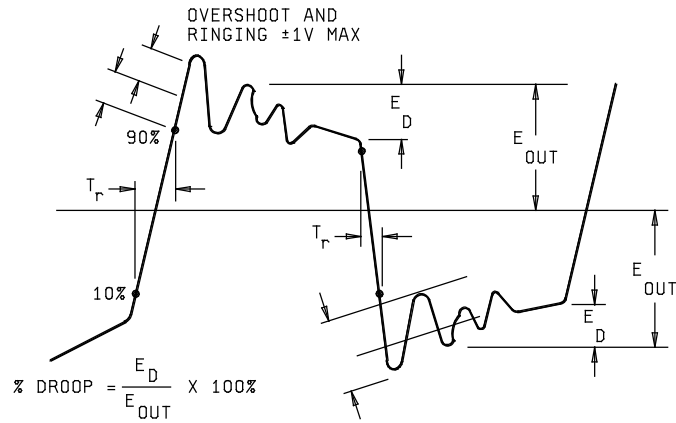
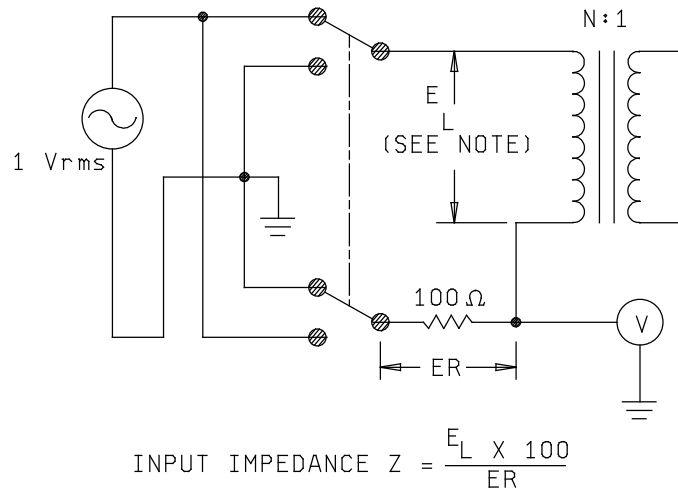

FIGURE 4. Output wave form for test circuit on figure 3.



NOTE: Input to be applied to high-turn side of all dash numbers. Self impedance may also be measured using Agilent 4284A LCZ meter or equivalent. N represents the highest turn winding.

FIGURE 5. Test circuit for input impedance.

MIL-PRF-21038/27E
W/AMENDMENT 3

TABLE I. Electrical characteristics and configurations.

Dash number	Turns ratio ($\pm 3\%$) $\frac{1}{1}$	Primary	Secondary	Percent droop (max)	CMR (min)	DC resistance ohms (max)	Impedance ohms (min)	Configuration
-01	1:1 1:1.707	1-3 1-3	4-8 5-7	20	45 dB	1-3 3.0 4-8 3.0	(1-3) 4,000	A
-02	1.4:1 2:1	1-3 1-3	4-8 5-7	20	45 dB	1-3 3.5 4-8 3.0	(1-3) 7,200	A
-03	1.25:1 1.66:1	1-3 1-3	4-8 5-7	20	45 dB	1-3 3.2 4-8 3.0	(1-3) 4,000	A
-04	2.3:1 3.2:1	4-8 5-7	1-3 1-3	20	45 dB	1-3 1.2 4-8 3.0	(5-7) 3,000	A
-05	1:1.41	1-2	3-4	20	45 dB	1-2 2.2 3-4 2.7	(3-4) 3,000	C
-06	1:1	1-5	2-6	20	45 dB	1-5 2.5 2-6 2.8	(1-5) 3,000	B
-07	1:1.41	1-5	2-6	20	45 dB	1-5 2.2 2-6 2.7	(2-6) 3,000	B
-08	1:1.66	1-5	2-6	20	45 dB	1-5 1.5 2-6 2.4	(2-6) 3,000	B
-09	1:2	1-5	2-6	20	45 dB	1-5 1.3 2-6 2.6	(2-6) 3,000	B
-10	1:2.12 1:1.5	1-3 1-3	4-8 5-7	20	45 dB	1-3 1.0 4-8 3.5	(4-8) 4,000	A
-11	1:1 1:1.707	1-3 1-3	4-8 5-7	20	45 dB	1-3 3.0 4-8 3.0	(1-3) 4,000	D
-12	1.4:1 2:1	1-3 1-3	4-8 5-7	20	45 dB	1-3 3.5 4-8 3.0	(1-3) 7,200	D

See footnote at end of table.

MIL-PRF-21038/27E
W/AMENDMENT 3

TABLE I. Electrical characteristics and configurations - Continued.

Dash number	Turns ratio ($\pm 3\%$) 1/	Primary	Secondary	Percent droop (max)	CMR (min)	DC resistance ohms (max)	Impedance ohms (min)	Configuration
-13	1.25:1 1.66:1	1-3 1-3	4-8 5-7	20	45 dB	1-3 3.2 4-8 3.0	(1-3) 4,000	D
-14	2.3:1 3.2:1	4-8 5-7	1-3 1-3	20	45 dB	1-3 1.2 4-8 3.0	(5-7) 3,000	D
-15	1:2.12 1:1.5	1-3 1-3	4-8 5-7	20	45 dB	1-3 1.0 4-8 3.5	(4-8) 4,000	D
-16	1:1 1:1.707	1-3 1-3	4-8 5-7	20	45 dB	1-3 3.0 4-8 3.0	(1-3) 4,000	E
-17	1.4:1 2:1	1-3 1-3	4-8 5-7	20	45 dB	1-3 3.5 4-8 3.0	(1-3) 7,200	E
-18	1.25:1 1.66:1	1-3 1-3	4-8 5-7	20	45 dB	1-3 3.2 4-8 3.0	(1-3) 4,000	E
-19	2.3:1 3.2:1	4-8 5-7	1-3 1-3	20	45 dB	1-3 1.2 4-8 3.0	(5-7) 3,000	E
-20	1:2.12 1:1.5	1-3 1-3	4-8 5-7	20	45 dB	1-3 1.0 4-8 3.5	(4-8) 3,000	E
-21	1:1 1:1.707	1-3 1-3	4-8 5-7	20	45 dB	1-3 3.0 4-8 3.0	(1-3) 4,000	F
-22	1.4:1 2:1	1-3 1-3	4-8 5-7	20	45 dB	1-3 3.5 4-8 3.0	(1-3) 7,200	F
-23	1.25:1 1.66:1	1-3 1-3	4-8 5-7	20	45 dB	1-3 3.2 4-8 3.0	(1-3) 4,000	F
-24	1:2.12 1:1.5	1-3 1-3	4-8 5-7	20	45 dB	1-3 1.0 4-8 3.5	(4-8) 4,000	F
-25	1:2.5 1:1.79	1-3 1-3	4-8 5-7	20	45 dB	1-3 1.0 4-8 3.5	(4-8) 4,000	F

See footnote at end of table.

MIL-PRF-21038/27E
W/AMENDMENT 3

TABLE I. Electrical characteristics and configurations - Continued.

Dash number	Turns ratio ($\pm 3\%$) 1/	Primary	Secondary	Percent droop (max)	CMR (min)	DC resist-ance ohms (max)	Imped-ance ohms (min)	Config-uration
-26	1:2.5 1:1.79	1-3 1-3	4-8 5-7	20	45 dB	1-3 1.0 4-8 3.5	(4-8) 4,000	A
-27	1:2.5 1:1.79	1-3 1-3	4-8 5-7	20	45 dB	1-3 1.0 4-8 3.5	(4-8) 4,000	D
-28	1:1.5	1-5	2-6	20	45 dB	1-5 .90 2-6 2.5	(2-6) 3,000	B
-29	1:1.79	1-5	2-6	20	45 dB	1-5 .90 2-6 2.5	(2-6) 3,000	B
-30	1:2.5	1-5	2-6	20	45 dB	1-5 1.0 2-6 2.8	(2-6) 3,000	B
-31	1:2.5 1:1.79	1-3 1-3	4-8 5-7	20	45 dB	1-3 1.0 4-8 3.5	(4-8) 4,000	E

1/ Primary, secondary on all parts except M21038/27-05, shall have center tap balance to ± 5 percent.

MIL-PRF-21038/27E
W/AMENDMENT 3

Amendment notations. The margins of this specification are marked with vertical lines to indicate modifications generated by this amendment. This was done as a convenience only and the Government assumes no liability whatsoever for any inaccuracies in these notations. Bidders and contractors are cautioned to evaluate the requirements of this document based on the entire content irrespective of the marginal notations.

Referenced documents. In addition to MIL-PRF-21038, this document references the following:

MIL-STD-202-204, MIL-STD-202-211, MIL-STD-202-213, MIL-STD-202-301, MIL-STD-202-302

Custodians:

Army - CR
Navy - EC
Air Force - 85
DLA - CC

Preparing activity:

DLA - CC

(Project 5950-2022-057)

Review activities:

Army - AM, AR, CR4, MI
Navy - AS, MC, OS, SH
Air Force - 19

NOTE: The activities listed above were interested in this document as of the date of this document. Since organizations and responsibilities can change, you should verify the currency of the information above using the ASSIST Online database at <https://assist.dla.mil>.